

Electric motors: In a dc motor a magnetic field exerts a torque on a current in the rotor. Motion of the rotor through the magnetic field causes an induced emf called a back emf. For a series motor, in which the rotor coil is in parallel with coils that produce the magnetic field, the terminal voltage is the sum of the back emf and the drop Ir across the internal resistance. (See Example 27.11.)

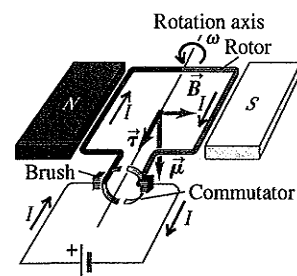

The Hall effect: The Hall effect is a potential difference perpendicular to the direction of current in a conductor, when the conductor is placed in a magnetic field. The Hall potential is determined by the requirement that the associated electric field must just balance the magnetic force on a moving charge. Hall-effect measurements can be used to determine the sign of charge carriers and their concentration n . (See Example 27.12.)

$$nq = \frac{-J_x B_y}{E_z} \quad (27.30)$$

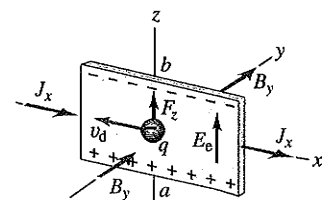

BRIDGING PROBLEM Magnetic Torque on a Current-Carrying Ring

A circular ring with area 4.45 cm^2 is carrying a current of 12.5 A . The ring, initially at rest, is immersed in a region of uniform magnetic field given by $\vec{B} = (1.15 \times 10^{-2} \text{ T})(12\hat{i} + 3\hat{j} - 4\hat{k})$. The ring is positioned initially such that its magnetic moment is given by $\vec{\mu}_i = \mu(-0.800\hat{i} + 0.600\hat{j})$, where μ is the (positive) magnitude of the magnetic moment. (a) Find the initial magnetic torque on the ring. (b) The ring (which is free to rotate around one diameter) is released and turns through an angle of 90.0° , at which point its magnetic moment is given by $\vec{\mu}_f = -\mu\hat{k}$. Determine the decrease in potential energy. (c) If the moment of inertia of the ring about a diameter is $8.50 \times 10^{-7} \text{ kg} \cdot \text{m}^2$, determine the angular speed of the ring as it passes through the second position.

SOLUTION GUIDE

See MasteringPhysics® study area for a Video Tutor solution.



IDENTIFY and SET UP

- The current-carrying ring acts as a magnetic dipole, so you can use the equations for a magnetic dipole in a uniform magnetic field.

- There are no nonconservative forces acting on the ring as it rotates, so the sum of its rotational kinetic energy (discussed in Section 9.4) and the potential energy is conserved.

EXECUTE

- Use the vector expression for the torque on a magnetic dipole to find the answer to part (a). (*Hint:* You may want to review Section 1.10.)
- Find the change in potential energy from the first orientation of the ring to the second orientation.
- Use your result from step 4 to find the rotational kinetic energy of the ring when it is in the second orientation.
- Use your result from step 5 to find the ring's angular speed when it is in the second orientation.

EVALUATE

- If the ring were free to rotate around *any* diameter, in what direction would the magnetic moment point when the ring is in a state of stable equilibrium?

Problems

For instructor-assigned homework, go to www.masteringphysics.com



•, ••, •••: Problems of increasing difficulty. **CP**: Cumulative problems incorporating material from earlier chapters. **CALC**: Problems requiring calculus. **BIU**: Biosciences problems.

DISCUSSION QUESTIONS

- Q27.1** Can a charged particle move through a magnetic field without experiencing any force? If so, how? If not, why not?
- Q27.2** At any point in space, the electric field \vec{E} is defined to be in the direction of the electric force on a positively charged particle at that point. Why don't we similarly define the magnetic field \vec{B} to

be in the direction of the magnetic force on a moving, positively charged particle?

- Q27.3** Section 27.2 describes a procedure for finding the direction of the magnetic force using your right hand. If you use the same procedure, but with your left hand, will you get the correct direction for the force? Explain.

Q27.4 The magnetic force on a moving charged particle is always perpendicular to the magnetic field \vec{B} . Is the trajectory of a moving charged particle always perpendicular to the magnetic field lines? Explain your reasoning.

Q27.5 A charged particle is fired into a cubical region of space where there is a uniform magnetic field. Outside this region, there is no magnetic field. Is it possible that the particle will remain inside the cubical region? Why or why not?

Q27.6 If the magnetic force does no work on a charged particle, how can it have any effect on the particle's motion? Are there other examples of forces that do no work but have a significant effect on a particle's motion?

Q27.7 A charged particle moves through a region of space with constant velocity (magnitude and direction). If the external magnetic field is zero in this region, can you conclude that the external electric field in the region is also zero? Explain. (By "external" we mean fields other than those produced by the charged particle.) If the external electric field is zero in the region, can you conclude that the external magnetic field in the region is also zero?

Q27.8 How might a loop of wire carrying a current be used as a compass? Could such a compass distinguish between north and south? Why or why not?

Q27.9 How could the direction of a magnetic field be determined by making only *qualitative* observations of the magnetic force on a straight wire carrying a current?

Q27.10 A loose, floppy loop of wire is carrying current I . The loop of wire is placed on a horizontal table in a uniform magnetic field \vec{B} perpendicular to the plane of the table. This causes the loop of wire to expand into a circular shape while still lying on the table. In a diagram, show all possible orientations of the current I and magnetic field \vec{B} that could cause this to occur. Explain your reasoning.

Q27.11 Several charges enter a uniform magnetic field directed into the page. (a) What path would a positive charge q moving with a velocity of magnitude v follow through the field? (b) What path would a positive charge q moving with a velocity of magnitude $2v$ follow through the field? (c) What path would a negative charge $-q$ moving with a velocity of magnitude v follow through the field? (d) What path would a neutral particle follow through the field?

Q27.12 Each of the lettered points at the corners of the cube in Fig. Q27.12 represents a positive charge q moving with a velocity of magnitude v in the direction indicated. The region in the figure is in a uniform magnetic field \vec{B} , parallel to the x -axis and directed toward the right. Which charges experience a force due to \vec{B} ? What is the direction of the force on each charge?

Figure Q27.12

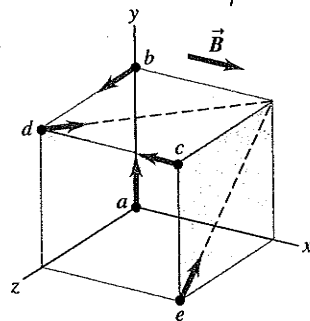

Q27.13 A student claims that if lightning strikes a metal flagpole, the force exerted by the earth's magnetic field on the current in the pole can be large enough to bend it. Typical lightning currents are of the order of 10^4 to 10^5 A. Is the student's opinion justified? Explain your reasoning.

Q27.14 Could an accelerator be built in which *all* the forces on the particles, for steering and for increasing speed, are magnetic forces? Why or why not?

Q27.15 An ordinary loudspeaker such as that shown in Fig. 27.28 should not be placed next to a computer monitor or TV screen. Why not?

Q27.16 The magnetic force acting on a charged particle can never do work because at every instant the force is perpendicular to the velocity. The torque exerted by a magnetic field can do work on a current loop when the loop rotates. Explain how these seemingly contradictory statements can be reconciled.

Q27.17 If an emf is produced in a dc motor, would it be possible to use the motor somehow as a generator or source, taking power out of it rather than putting power into it? How might this be done?

Q27.18 When the polarity of the voltage applied to a dc motor is reversed, the direction of motion does *not* reverse. Why not? How *could* the direction of motion be reversed?

Q27.19 In a Hall-effect experiment, is it possible that *no* transverse potential difference will be observed? Under what circumstances might this happen?

Q27.20 Hall-effect voltages are much greater for relatively poor conductors (such as germanium) than for good conductors (such as copper), for comparable currents, fields, and dimensions. Why?

EXERCISES

Section 27.2 Magnetic Field

27.1 • A particle with a charge of -1.24×10^{-8} C is moving with instantaneous velocity $\vec{v} = (4.19 \times 10^4 \text{ m/s})\hat{i} + (-3.85 \times 10^4 \text{ m/s})\hat{j}$. What is the force exerted on this particle by a magnetic field (a) $\vec{B} = (1.40 \text{ T})\hat{i}$ and (b) $\vec{B} = (1.40 \text{ T})\hat{k}$?

27.2 • A particle of mass 0.195 g carries a charge of -2.50×10^{-8} C. The particle is given an initial horizontal velocity that is due north and has magnitude 4.00×10^4 m/s. What are the magnitude and direction of the minimum magnetic field that will keep the particle moving in the earth's gravitational field in the same horizontal, northward direction?

27.3 • In a 1.25-T magnetic field directed vertically upward, a particle having a charge of magnitude $8.50 \mu\text{C}$ and initially moving northward at 4.75 km/s is deflected toward the east. (a) What is the sign of the charge of this particle? Make a sketch to illustrate how you found your answer. (b) Find the magnetic force on the particle.

27.4 • A particle with mass 1.81×10^{-3} kg and a charge of 1.22×10^{-8} C has, at a given instant, a velocity $\vec{v} = (3.00 \times 10^4 \text{ m/s})\hat{j}$. What are the magnitude and direction of the particle's acceleration produced by a uniform magnetic field $\vec{B} = (1.63 \text{ T})\hat{i} + (0.980 \text{ T})\hat{j}$?

27.5 • An electron experiences a magnetic force of magnitude 4.60×10^{-15} N when moving at an angle of 60.0° with respect to a magnetic field of magnitude 3.50×10^{-3} T. Find the speed of the electron.

27.6 • An electron moves at 2.50×10^6 m/s through a region in which there is a magnetic field of unspecified direction and magnitude 7.40×10^{-2} T. (a) What are the largest and smallest possible magnitudes of the acceleration of the electron due to the magnetic field? (b) If the actual acceleration of the electron is one-fourth of the largest magnitude in part (a), what is the angle between the electron velocity and the magnetic field?

27.7 • CP A particle with charge $7.80 \mu\text{C}$ is moving with velocity $\vec{v} = -(3.80 \times 10^3 \text{ m/s})\hat{j}$. The magnetic force on the particle is measured to be $\vec{F} = +(7.60 \times 10^{-3} \text{ N})\hat{i} - (5.20 \times 10^{-3} \text{ N})\hat{k}$. (a) Calculate all the components of the magnetic field you can from this information. (b) Are there components of the magnetic field that are not determined by the measurement of the force? Explain. (c) Calculate the scalar product $\vec{B} \cdot \vec{F}$. What is the angle between \vec{B} and \vec{F} ?

27.8 • CP A particle with charge -5.60 nC is moving in a uniform magnetic field $\vec{B} = -(1.25 \text{ T})\hat{k}$. The magnetic force on the

particle is measured to be $\vec{F} = -(3.40 \times 10^{-7} \text{ N})\hat{i} + (7.40 \times 10^{-7} \text{ N})\hat{j}$. (a) Calculate all the components of the velocity of the particle that you can from this information. (b) Are there components of the velocity that are not determined by the measurement of the force? Explain. (c) Calculate the scalar product $\vec{v} \cdot \vec{F}$. What is the angle between \vec{v} and \vec{F} ?

27.9 •• A group of particles is traveling in a magnetic field of unknown magnitude and direction. You observe that a proton moving at 1.50 km/s in the $+x$ -direction experiences a force of $2.25 \times 10^{-16} \text{ N}$ in the $+y$ -direction, and an electron moving at 4.75 km/s in the $-z$ -direction experiences a force of $8.50 \times 10^{-16} \text{ N}$ in the $+y$ -direction. (a) What are the magnitude and direction of the magnetic field? (b) What are the magnitude and direction of the magnetic force on an electron moving in the $-y$ -direction at 3.20 km/s?

Section 27.3 Magnetic Field Lines and Magnetic Flux

27.10 • A flat, square surface with side length 3.40 cm is in the xy -plane at $z = 0$. Calculate the magnitude of the flux through this surface produced by a magnetic field $\vec{B} = (0.200 \text{ T})\hat{i} + (0.300 \text{ T})\hat{j} - (0.500 \text{ T})\hat{k}$.

27.11 • A circular area with a radius of 6.50 cm lies in the xy -plane. What is the magnitude of the magnetic flux through this circle due to a uniform magnetic field $B = 0.230 \text{ T}$ (a) in the $+z$ -direction; (b) at an angle of 53.1° from the $+z$ -direction; (c) in the $+y$ -direction?

27.12 • A horizontal rectangular surface has dimensions 2.80 cm by 3.20 cm and is in a uniform magnetic field that is directed at an angle of 30.0° above the horizontal. What must the magnitude of the magnetic field be in order to produce a flux of $4.20 \times 10^{-4} \text{ Wb}$ through the surface?

27.13 •• An open plastic soda bottle with an opening diameter of 2.5 cm is placed on a table. A uniform 1.75-T magnetic field directed upward and oriented 25° from vertical encompasses the bottle. What is the total magnetic flux through the plastic of the soda bottle?

27.14 •• The magnetic field \vec{B} in a certain region is 0.128 T, and its direction is that of the $+z$ -axis in Fig. E27.14. (a) What is the magnetic flux across the surface $abcd$ in the figure? (b) What is the magnetic flux across the surface $befc$? (c) What is the magnetic flux across the surface $aefd$? (d) What is the net flux through all five surfaces that enclose the shaded volume?

Figure E27.14

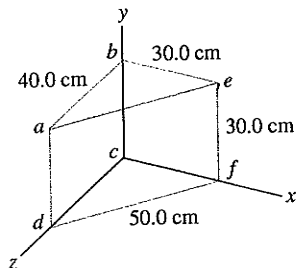

Section 27.4 Motion of Charged Particles in a Magnetic Field

27.15 •• An electron at point A in Fig. E27.15 has a speed v_0 of $1.41 \times 10^6 \text{ m/s}$. Find (a) the magnitude and direction of the magnetic field that will cause the electron to follow the semi-circular path from A to B, and (b) the time required for the electron to move from A to B.

Figure E27.15

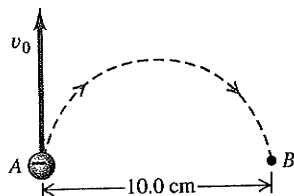

27.16 •• Repeat Exercise 27.15 for the case in which the particle is a proton rather than an electron.

27.17 • CP A 150-g ball containing 4.00×10^8 excess electrons is dropped into a 125-m vertical shaft. At the bottom of the shaft, the ball suddenly enters a uniform horizontal magnetic field that has magnitude 0.250 T and direction from east to west. If air resistance is negligibly small, find the magnitude and direction of the force that this magnetic field exerts on the ball just as it enters the field.

27.18 • An alpha particle (a He nucleus, containing two protons and two neutrons and having a mass of $6.64 \times 10^{-27} \text{ kg}$) traveling horizontally at 35.6 km/s enters a uniform, vertical, 1.10-T magnetic field. (a) What is the diameter of the path followed by this alpha particle? (b) What effect does the magnetic field have on the speed of the particle? (c) What are the magnitude and direction of the acceleration of the alpha particle while it is in the magnetic field? (d) Explain why the speed of the particle does not change even though an unbalanced external force acts on it.

27.19 • CP A particle with charge $6.40 \times 10^{-19} \text{ C}$ travels in a circular orbit with radius 4.68 mm due to the force exerted on it by a magnetic field with magnitude 1.65 T and perpendicular to the orbit. (a) What is the magnitude of the linear momentum \vec{p} of the particle? (b) What is the magnitude of the angular momentum \vec{L} of the particle?

27.20 • (a) An ^{16}O nucleus (charge $+8e$) moving horizontally from west to east with a speed of 500 km/s experiences a magnetic force of 0.00320 nN vertically downward. Find the magnitude and direction of the weakest magnetic field required to produce this force. Explain how this same force could be caused by a larger magnetic field. (b) An electron moves in a uniform, horizontal, 2.10-T magnetic field that is toward the west. What must the magnitude and direction of the minimum velocity of the electron be so that the magnetic force on it will be 4.60 pN, vertically upward? Explain how the velocity could be greater than this minimum value and the force still have this same magnitude and direction.

27.21 • A deuteron (the nucleus of an isotope of hydrogen) has a mass of $3.34 \times 10^{-27} \text{ kg}$ and a charge of $+e$. The deuteron travels in a circular path with a radius of 6.96 mm in a magnetic field with magnitude 2.50 T. (a) Find the speed of the deuteron. (b) Find the time required for it to make half a revolution. (c) Through what potential difference would the deuteron have to be accelerated to acquire this speed?

27.22 • In an experiment with cosmic rays, a vertical beam of particles that have charge of magnitude $3e$ and mass 12 times the proton mass enters a uniform horizontal magnetic field of 0.250 T and is bent in a semicircle of diameter 95.0 cm, as shown in Fig. E27.22.

Figure E27.22

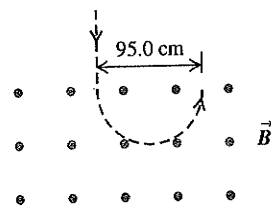

(a) Find the speed of the particles and the sign of their charge. (b) Is it reasonable to ignore the gravity force on the particles? (c) How does the speed of the particles as they enter the field compare to their speed as they exit the field?

27.23 • A physicist wishes to produce electromagnetic waves of frequency 3.0 THz (1 THz = 1 terahertz = 10^{12} Hz) using a magnetron (see Example 27.3). (a) What magnetic field would be required? Compare this field with the strongest constant magnetic fields yet produced on earth, about 45 T. (b) Would there be any advantage to using protons instead of electrons in the magnetron? Why or why not?

27.24 •• A beam of protons traveling at 1.20 km/s enters a uniform magnetic field, traveling perpendicular to the field. The beam exits the magnetic field, leaving the field in a direction perpendicular to its original direction (Fig. E27.24). The beam travels a distance of 1.18 cm while in the field. What is the magnitude of the magnetic field?

Figure E27.24

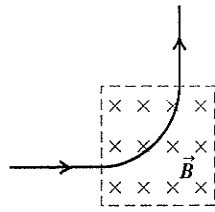

27.25 • An electron in the beam of a TV picture tube is accelerated by a potential difference of 2.00 kV. Then it passes through a region of transverse magnetic field, where it moves in a circular arc with radius 0.180 m. What is the magnitude of the field?

27.26 • A singly charged ion of ${}^7\text{Li}$ (an isotope of lithium) has a mass of 1.16×10^{-26} kg. It is accelerated through a potential difference of 220 V and then enters a magnetic field with magnitude 0.723 T perpendicular to the path of the ion. What is the radius of the ion's path in the magnetic field?

27.27 •• A proton ($q = 1.60 \times 10^{-19}$ C, $m = 1.67 \times 10^{-27}$ kg) moves in a uniform magnetic field $\vec{B} = (0.500 \text{ T})\hat{i}$. At $t = 0$ the proton has velocity components $v_x = 1.50 \times 10^5$ m/s, $v_y = 0$, and $v_z = 2.00 \times 10^5$ m/s (see Example 27.4). (a) What are the magnitude and direction of the magnetic force acting on the proton? In addition to the magnetic field there is a uniform electric field in the $+x$ -direction, $\vec{E} = (+2.00 \times 10^4 \text{ V/m})\hat{i}$. (b) Will the proton have a component of acceleration in the direction of the electric field? (c) Describe the path of the proton. Does the electric field affect the radius of the helix? Explain. (d) At $t = T/2$, where T is the period of the circular motion of the proton, what is the x -component of the displacement of the proton from its position at $t = 0$?

Section 27.5 Applications of Motion of Charged Particles

27.28 • (a) What is the speed of a beam of electrons when the simultaneous influence of an electric field of 1.56×10^4 V/m and a magnetic field of 4.62×10^{-3} T, with both fields normal to the beam and to each other, produces no deflection of the electrons? (b) In a diagram, show the relative orientation of the vectors \vec{v} , \vec{E} , and \vec{B} . (c) When the electric field is removed, what is the radius of the electron orbit? What is the period of the orbit?

27.29 • In designing a velocity selector that uses uniform perpendicular electric and magnetic fields, you want to select positive ions of charge $+5e$ that are traveling perpendicular to the fields at 8.75 km/s. The magnetic field available to you has a magnitude of 0.550 T. (a) What magnitude of electric field do you need? (b) Show how the two fields should be oriented relative to each other and to the velocity of the ions. (c) Will your velocity selector also allow the following ions (having the same velocity as the $+5e$ ions) to pass through undeflected: (i) negative ions of charge $-5e$, (ii) positive ions of charge different from $+5e$?

27.30 • **Crossed \vec{E} and \vec{B} Fields.** A particle with initial velocity $\vec{v}_0 = (5.85 \times 10^3 \text{ m/s})\hat{j}$ enters a region of uniform electric and magnetic fields. The magnetic field in the region is $\vec{B} = -(1.35 \text{ T})\hat{k}$. Calculate the magnitude and direction of the electric field in the region if the particle is to pass through undeflected, for a particle of charge (a) $+0.640$ nC and (b) -0.320 nC. You can ignore the weight of the particle.

27.31 •• A 150-V battery is connected across two parallel metal plates of area 28.5 cm^2 and separation 8.20 mm. A beam of alpha particles (charge $+2e$, mass 6.64×10^{-27} kg) is accelerated from

rest through a potential difference of 1.75 kV and enters the region between the plates perpendicular to the electric field, as shown in Fig. E27.31. What magnitude and direction of magnetic field are needed so that the alpha particles emerge undeflected from between the plates?

Figure E27.31

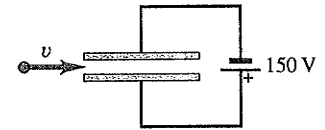

27.32 • A singly ionized (one electron removed) ${}^{40}\text{K}$ atom passes through a velocity selector consisting of uniform perpendicular electric and magnetic fields. The selector is adjusted to allow ions having a speed of 4.50 km/s to pass through undeflected when the magnetic field is 0.0250 T. The ions next enter a second uniform magnetic field (B') oriented at right angles to their velocity. ${}^{40}\text{K}$ contains 19 protons and 21 neutrons and has a mass of 6.64×10^{-26} kg. (a) What is the magnitude of the electric field in the velocity selector? (b) What must be the magnitude of B' so that the ions will be bent into a semicircle of radius 12.5 cm?

27.33 • Singly ionized (one electron removed) atoms are accelerated and then passed through a velocity selector consisting of perpendicular electric and magnetic fields. The electric field is 155 V/m and the magnetic field is 0.0315 T. The ions next enter a uniform magnetic field of magnitude 0.0175 T that is oriented perpendicular to their velocity. (a) How fast are the ions moving when they emerge from the velocity selector? (b) If the radius of the path of the ions in the second magnetic field is 17.5 cm, what is their mass?

27.34 • In the Bainbridge mass spectrometer (see Fig. 27.24), the magnetic-field magnitude in the velocity selector is 0.650 T, and ions having a speed of 1.82×10^6 m/s pass through undeflected. (a) What is the electric-field magnitude in the velocity selector? (b) If the separation of the plates is 5.20 mm, what is the potential difference between plates P and P' ?

27.35 •• **Blü Ancient Meat Eating.** The amount of meat in prehistoric diets can be determined by measuring the ratio of the isotopes nitrogen-15 to nitrogen-14 in bone from human remains. Carnivores concentrate ${}^{15}\text{N}$, so this ratio tells archaeologists how much meat was consumed by ancient people. Use the spectrometer of Exercise 27.34 to find the separation of the ${}^{14}\text{N}$ and ${}^{15}\text{N}$ isotopes at the detector. The measured masses of these isotopes are 2.32×10^{-26} kg (${}^{14}\text{N}$) and 2.49×10^{-26} kg (${}^{15}\text{N}$).

Section 27.6 Magnetic Force on a Current-Carrying Conductor

27.36 • A straight, 2.5-m wire carries a typical household current of 1.5 A (in one direction) at a location where the earth's magnetic field is 0.55 gauss from south to north. Find the magnitude and direction of the force that our planet's magnetic field exerts on this wire if it is oriented so that the current in it is running (a) from west to east, (b) vertically upward, (c) from north to south. (d) Is the magnetic force ever large enough to cause significant effects under normal household conditions?

27.37 • A straight, 2.00-m, 150-g wire carries a current in a region where the earth's magnetic field is horizontal with a magnitude of 0.55 gauss. (a) What is the minimum value of the current in this wire so that its weight is completely supported by the magnetic force due to earth's field, assuming that no other forces except gravity act on it? Does it seem likely that such a wire could support this size of current? (b) Show how the wire would have to be oriented relative to the earth's magnetic field to be supported in this way.

27.38 •• An electromagnet produces a magnetic field of 0.550 T in a cylindrical region of radius 2.50 cm between its poles. A straight wire carrying a current of 10.8 A passes through the center of this region and is perpendicular to both the axis of the cylindrical region and the magnetic field. What magnitude of force is exerted on the wire?

27.39 •• A long wire carrying 4.50 A of current makes two 90° bends, as shown in Fig. E27.39. The bent part of the wire passes through a uniform 0.240-T magnetic field directed as shown in the figure and confined to a limited region of space. Find the magnitude and direction of the force that the magnetic field exerts on the wire.

Figure E27.39

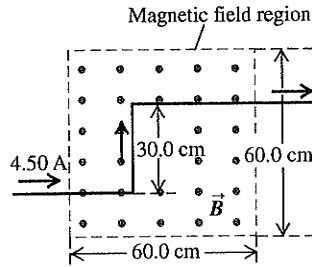

27.40 • A straight, vertical wire carries a current of 1.20 A downward in a region between the poles of a large superconducting electromagnet, where the magnetic field has magnitude $B = 0.588$ T and is horizontal. What are the magnitude and direction of the magnetic force on a 1.00-cm section of the wire that is in this uniform magnetic field, if the magnetic field direction is (a) east; (b) south; (c) 30.0° south of west?

27.41 • A thin, 50.0-cm-long metal bar with mass 750 g rests on, but is not attached to, two metallic supports in a uniform 0.450-T magnetic field, as shown in Fig. E27.41. A battery and a 25.0-Ω resistor in series are connected to the supports. (a) What is the highest voltage the battery can have without breaking the circuit at the supports? (b) The battery voltage has the maximum value calculated in part (a). If the resistor suddenly gets partially short-circuited, decreasing its resistance to 2.0 Ω, find the initial acceleration of the bar.

Figure E27.41

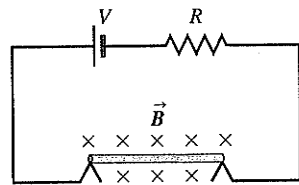

27.42 • Magnetic Balance.

The circuit shown in Fig. E27.42 is used to make a magnetic balance to weigh objects. The mass m to be measured is hung from the center of the bar that is in a uniform magnetic field of 1.50 T, directed into the plane of the figure. The battery voltage can be adjusted to vary the current in the circuit. The horizontal bar is 60.0 cm long and is made of extremely light-weight material. It is connected to the battery by thin vertical wires that can support no appreciable tension; all the weight of the suspended mass m is supported by the magnetic force on the bar. A resistor with $R = 5.00$ Ω is in series with the bar; the resistance of the rest of the circuit is much less than this. (a) Which point, a or b , should be the positive terminal of the battery? (b) If the maximum terminal voltage of the battery is 175 V, what is the greatest mass m that this instrument can measure?

Figure E27.42

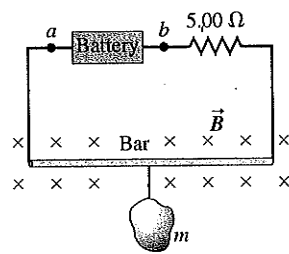

27.43 • Consider the conductor and current in Example 27.8, but now let the magnetic field be parallel to the x -axis. (a) What are the magnitude and direction of the total magnetic force on the conductor? (b) In Example 27.8, the total force is the same as if we replaced the semicircle with a straight segment along the x -axis. Is

that still true when the magnetic field is in this different direction? Can you explain why, or why not?

Section 27.7 Force and Torque on a Current Loop

27.44 •• The plane of a 5.0 cm × 8.0 cm rectangular loop of wire is parallel to a 0.19-T magnetic field. The loop carries a current of 6.2 A. (a) What torque acts on the loop? (b) What is the magnetic moment of the loop? (c) What is the maximum torque that can be obtained with the same total length of wire carrying the same current in this magnetic field?

27.45 • The 20.0 cm × 35.0 cm rectangular circuit shown in Fig. E27.45 is hinged along side ab . It carries a clockwise 5.00-A current and is located in a uniform 1.20-T magnetic field oriented perpendicular to two of its sides, as shown. (a) Draw a clear diagram showing the direction of the force that the magnetic field exerts on each segment of the circuit (ab , bc , etc.). (b) Of the four forces you drew in part (a), decide which ones exert a torque about the hinge ab . Then calculate only those forces that exert this torque. (c) Use your results from part (b) to calculate the torque that the magnetic field exerts on the circuit about the hinge axis ab .

Figure E27.45

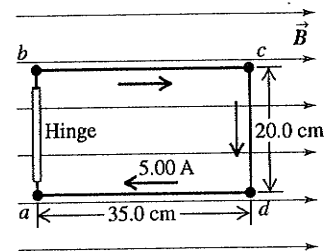

27.46 • A rectangular coil of wire, 22.0 cm by 35.0 cm and carrying a current of 1.40 A, is oriented with the plane of its loop perpendicular to a uniform 1.50-T magnetic field, as shown in Fig. E27.46. (a) Calculate the net force and torque that the magnetic field exerts on the coil.

Figure E27.46

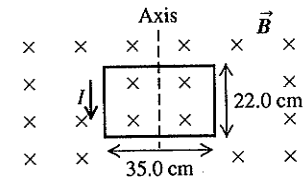

(b) The coil is rotated through a 30.0° angle about the axis shown, with the left side coming out of the plane of the figure and the right side going into the plane. Calculate the net force and torque that the magnetic field now exerts on the coil. (Hint: In order to help visualize this three-dimensional problem, make a careful drawing of the coil as viewed along the rotation axis.)

27.47 • CP A uniform rectangular coil of total mass 212 g and dimensions 0.500 m × 1.00 m is oriented with its plane parallel to a uniform 3.00-T magnetic field (Fig. E27.47). A current of 2.00 A is suddenly started in the coil. (a) About which axis (A_1 or A_2) will the coil begin to rotate? Why? (b) Find the initial angular acceleration of the coil just after the current is started.

Figure E27.47

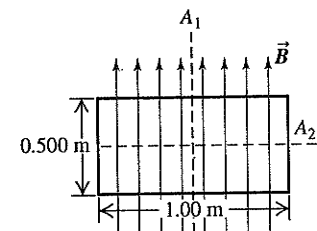

27.48 • A circular coil with area A and N turns is free to rotate about a diameter that coincides with the x -axis. Current I is circulating in the coil. There is a uniform magnetic field \vec{B} in the positive y -direction. Calculate the magnitude and direction of the torque $\vec{\tau}$

Figure E27.48

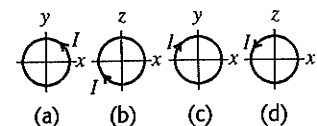

and the value of the potential energy U , as given in Eq. (27.27), when the coil is oriented as shown in parts (a) through (d) of Fig. E27.48.

27.49 •• A coil with magnetic moment $1.45 \text{ A} \cdot \text{m}^2$ is oriented initially with its magnetic moment antiparallel to a uniform 0.835-T magnetic field. What is the change in potential energy of the coil when it is rotated 180° so that its magnetic moment is parallel to the field?

Section 27.8 The Direct-Current Motor

27.50 • A dc motor with its rotor and field coils connected in series has an internal resistance of 3.2Ω . When the motor is running at full load on a 120-V line, the emf in the rotor is 105 V . (a) What is the current drawn by the motor from the line? (b) What is the power delivered to the motor? (c) What is the mechanical power developed by the motor?

27.51 •• In a shunt-wound dc motor with the field coils and rotor connected in parallel (Fig. E27.51), the resistance R_f of the field coils is 106Ω , and the resistance R_r of the rotor is 5.9Ω . When a potential difference of 120 V is applied to the brushes and the motor is running at full speed delivering mechanical power, the current supplied to it is 4.82 A . (a) What is the current in the field coils? (b) What is the current in the rotor? (c) What is the induced emf developed by the motor? (d) How much mechanical power is developed by this motor?

Figure E27.51

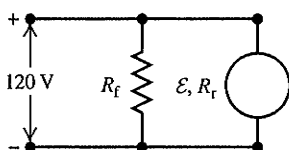

27.52 • A shunt-wound dc motor with the field coils and rotor connected in parallel (see Fig. E27.51) operates from a 120-V dc power line. The resistance of the field windings, R_f , is 218Ω . The resistance of the rotor, R_r , is 5.9Ω . When the motor is running, the rotor develops an emf \mathcal{E} . The motor draws a current of 4.82 A from the line. Friction losses amount to 45.0 W . Compute (a) the field current; (b) the rotor current; (c) the emf \mathcal{E} ; (d) the rate of development of thermal energy in the field windings; (e) the rate of development of thermal energy in the rotor; (f) the power input to the motor; (g) the efficiency of the motor.

Section 27.9 The Hall Effect

27.53 • Figure E27.53 shows a portion of a silver ribbon with $z_1 = 11.8 \text{ mm}$ and $y_1 = 0.23 \text{ mm}$, carrying a current of 120 A in the $+x$ -direction. The ribbon lies in a uniform magnetic field, in the y -direction, with magnitude 0.95 T . Apply the simplified model of the Hall effect presented in Section 27.9. If there are 5.85×10^{28} free electrons per cubic meter, find (a) the magnitude of the drift velocity of the electrons in the x -direction; (b) the magnitude and direction of the electric field in the z -direction due to the Hall effect; (c) the Hall emf.

Figure E27.53

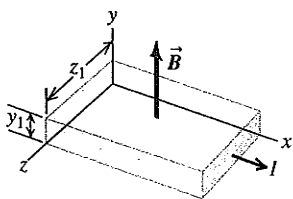

27.54 • Let Fig. E27.53 represent a strip of an unknown metal of the same dimensions as those of the silver ribbon in Exercise 27.53. When the magnetic field is 2.29 T and the current is 78.0 A , the Hall emf is found to be $131 \mu\text{V}$. What does the simplified model of the Hall effect presented in Section 27.9 give for the density of free electrons in the unknown metal?

PROBLEMS

27.55 • When a particle of charge $q > 0$ moves with a velocity of \vec{v}_1 at 45.0° from the $+x$ -axis in the xy -plane, a uniform magnetic field exerts a force \vec{F}_1 along the $-z$ -axis (Fig. P27.55). When the same particle moves with a velocity \vec{v}_2 with the same magnitude as \vec{v}_1 but along the $+z$ -axis, a force \vec{F}_2 of magnitude F_2 is exerted on it along the $+x$ -axis. (a) What are the magnitude (in terms of q , v_1 , and F_2) and direction of the magnetic field? (b) What is the magnitude of \vec{F}_1 in terms of F_2 ?

Figure P27.55

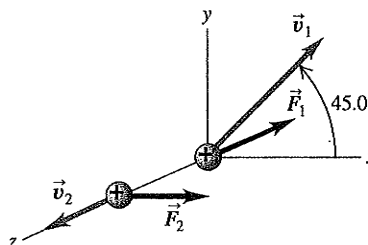

27.56 • A particle with charge $9.45 \times 10^{-8} \text{ C}$ is moving in a region where there is a uniform magnetic field of 0.650 T in the $+x$ -direction. At a particular instant of time the velocity of the particle has components $v_x = -1.68 \times 10^4 \text{ m/s}$, $v_y = -3.11 \times 10^4 \text{ m/s}$, and $v_z = 5.85 \times 10^4 \text{ m/s}$. What are the components of the force on the particle at this time?

27.57 ••• CP Fusion Reactor. If two deuterium nuclei (charge $+e$, mass $3.34 \times 10^{-27} \text{ kg}$) get close enough together, the attraction of the strong nuclear force will fuse them to make an isotope of helium, releasing vast amounts of energy. The range of this force is about 10^{-15} m . This is the principle behind the fusion reactor. The deuterium nuclei are moving much too fast to be contained by physical walls, so they are confined magnetically. (a) How fast would two nuclei have to move so that in a head-on collision they would get close enough to fuse? (Assume their speeds are equal. Treat the nuclei as point charges, and assume that a separation of $1.0 \times 10^{-15} \text{ m}$ is required for fusion.) (b) What strength magnetic field is needed to make deuterium nuclei with this speed travel in a circle of diameter 2.50 m ?

27.58 •• Magnetic Moment of the Hydrogen Atom. In the Bohr model of the hydrogen atom (see Section 38.5), in the lowest energy state the electron orbits the proton at a speed of $2.2 \times 10^6 \text{ m/s}$ in a circular orbit of radius $5.3 \times 10^{-11} \text{ m}$. (a) What is the orbital period of the electron? (b) If the orbiting electron is considered to be a current loop, what is the current I ? (c) What is the magnetic moment of the atom due to the motion of the electron?

27.59 •• You wish to hit a target from several meters away with a charged coin having a mass of 4.25 g and a charge of $+2500 \mu\text{C}$. The coin is given an initial velocity of 12.8 m/s , and a downward, uniform electric field with field strength 27.5 N/C exists throughout the region. If you aim directly at the target and fire the coin horizontally, what magnitude and direction of uniform magnetic field are needed in the region for the coin to hit the target?

27.60 • A cyclotron is to accelerate protons to an energy of 5.4 MeV . The superconducting electromagnet of the cyclotron produces a 2.9-T magnetic field perpendicular to the proton orbits. (a) When the protons have achieved a kinetic energy of 2.7 MeV , what is the radius of their circular orbit and what is their angular speed? (b) Repeat part (a) when the protons have achieved their final kinetic energy of 5.4 MeV .

27.61 • The magnetic poles of a small cyclotron produce a magnetic field with magnitude 0.85 T. The poles have a radius of 0.40 m, which is the maximum radius of the orbits of the accelerated particles. (a) What is the maximum energy to which protons ($q = 1.60 \times 10^{-19}$ C, $m = 1.67 \times 10^{-27}$ kg) can be accelerated by this cyclotron? Give your answer in electron volts and in joules. (b) What is the time for one revolution of a proton orbiting at this maximum radius? (c) What would the magnetic-field magnitude have to be for the maximum energy to which a proton can be accelerated to be twice that calculated in part (a)? (d) For $B = 0.85$ T, what is the maximum energy to which alpha particles ($q = 3.20 \times 10^{-19}$ C, $m = 6.65 \times 10^{-27}$ kg) can be accelerated by this cyclotron? How does this compare to the maximum energy for protons?

27.62 •• A particle with charge q is moving with speed v in the $-y$ -direction. It is moving in a uniform magnetic field $\vec{B} = B_x \hat{i} + B_y \hat{j} + B_z \hat{k}$. (a) What are the components of the force \vec{F} exerted on the particle by the magnetic field? (b) If $q > 0$, what must the signs of the components of \vec{B} be if the components of \vec{F} are all nonnegative? (c) If $q < 0$ and $B_x = B_y = B_z > 0$, find the direction of \vec{F} and find the magnitude of \vec{F} in terms of $|q|$, v , and B_x .

27.63 •• A particle with negative charge q and mass $m = 2.58 \times 10^{-15}$ kg is traveling through a region containing a uniform magnetic field $\vec{B} = -(0.120 \text{ T})\hat{k}$. At a particular instant of time the velocity of the particle is $\vec{v} = (1.05 \times 10^6 \text{ m/s})(-3\hat{i} + 4\hat{j} + 12\hat{k})$ and the force \vec{F} on the particle has a magnitude of 2.45 N. (a) Determine the charge q . (b) Determine the acceleration \vec{a} of the particle. (c) Explain why the path of the particle is a helix, and determine the radius of curvature R of the circular component of the helical path. (d) Determine the cyclotron frequency of the particle. (e) Although helical motion is not periodic in the full sense of the word, the x - and y -coordinates do vary in a periodic way. If the coordinates of the particle at $t = 0$ are $(x, y, z) = (R, 0, 0)$, determine its coordinates at a time $t = 2T$, where T is the period of the motion in the xy -plane.

27.64 •• **B10 Medical Uses of Cyclotrons.** The largest cyclotron in the United States is the *Tevatron* at Fermilab, near Chicago, Illinois. It is called a *Tevatron* because it can accelerate particles to energies in the TeV range: 1 tera-eV = 10^{12} eV. Its circumference is 6.4 km, and it currently can produce a maximum energy of 2.0 TeV. In a certain medical experiment, protons will be accelerated to energies of 1.25 MeV and aimed at a tumor to destroy its cells. (a) How fast are these protons moving when they hit the tumor? (b) How strong must the magnetic field be to bend the protons in the circle indicated?

27.65 • A magnetic field exerts a torque τ on a round current-carrying loop of wire. What will be the torque on this loop (in terms of τ) if its diameter is tripled?

27.66 •• A particle of charge $q > 0$ is moving at speed v in the $+z$ -direction through a region of uniform magnetic field \vec{B} . The magnetic force on the particle is $\vec{F} = F_0(3\hat{i} + 4\hat{j})$, where F_0 is a positive constant. (a) Determine the components B_x , B_y , and B_z , or at least as many of the three components as is possible from the information given. (b) If it is given in addition that the magnetic field has magnitude $6F_0/qv$, determine as much as you can about the remaining components of \vec{B} .

27.67 •• Suppose the electric field between the plates in Fig. 27.24 is 1.88×10^4 V/m and the magnetic field in both regions is 0.682 T. If the source contains the three isotopes of krypton, ^{82}Kr , ^{84}Kr , and ^{86}Kr , and the ions are singly charged, find the distance between the lines formed by the three isotopes on the particle

detector. Assume the atomic masses of the isotopes (in atomic mass units) are equal to their mass numbers, 82, 84, and 86. (One atomic mass unit = $1 \text{ u} = 1.66 \times 10^{-27}$ kg.)

27.68 •• **Mass Spectrograph.** A mass spectrograph is used to measure the masses of ions, or to separate ions of different masses (see Section 27.5). In one design for such an instrument, ions with mass m and charge q are accelerated through a potential difference V . They then enter a uniform magnetic field that is perpendicular to their velocity, and they are deflected in a semicircular path of radius R . A detector measures where the ions complete the semicircle and from this it is easy to calculate R . (a) Derive the equation for calculating the mass of the ion from measurements of B , V , R , and q . (b) What potential difference V is needed so that singly ionized ^{12}C atoms will have $R = 50.0$ cm in a 0.150-T magnetic field? (c) Suppose the beam consists of a mixture of ^{12}C and ^{14}C ions. If v and B have the same values as in part (b), calculate the separation of these two isotopes at the detector. Do you think that this beam separation is sufficient for the two ions to be distinguished? (Make the assumption described in Problem 27.67 for the masses of the ions.)

27.69 •• A straight piece of

conducting wire with mass M and length L is placed on a frictionless incline tilted at an angle θ from the horizontal (Fig. P27.69). There is a uniform, vertical magnetic field \vec{B} at all points (produced by an arrangement of magnets not shown in the figure). To keep the wire from sliding down the incline, a voltage source is attached to the ends of the wire. When just the right amount of current flows through the wire, the wire remains at rest. Determine the magnitude and direction of the current in the wire that will cause the wire to remain at rest. Copy the figure and draw the direction of the current on your copy. In addition, show in a free-body diagram all the forces that act on the wire.

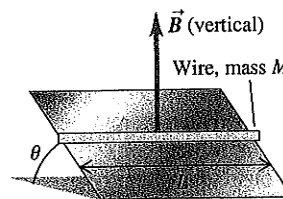

27.70 •• **CP** A 2.60-N metal bar, 1.50 m long and having a resistance of 10.0Ω , rests horizontally on conducting wires connecting it to the circuit shown in Fig. P27.70. The bar is in a uniform, horizontal, 1.60-T magnetic field and is not attached to the wires in the circuit. What is the acceleration of the bar just after the switch S is closed?

Figure P27.70

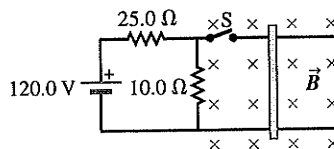

27.71 •• **Using Gauss's Law for Magnetism.** In a certain region of space, the magnetic field \vec{B} is not uniform. The magnetic field has both a z -component and a component that points radially away from or toward the z -axis. The z -component is given by $B_z(z) = \beta z$, where β is a positive constant. The radial component B_r depends only on r , the radial distance from the z -axis. (a) Use Gauss's law for magnetism, Eq. (27.8), to find the radial component B_r as a function of r . (Hint: Try a cylindrical Gaussian surface of radius r concentric with the z -axis, with one end at $z = 0$ and the other at $z = L$.) (b) Sketch the magnetic field lines.

27.72 •• CP A plastic circular loop has radius R , and a positive charge q is distributed uniformly around the circumference of the loop. The loop is then rotated around its central axis, perpendicular to the plane of the loop, with angular speed ω . If the loop is in a region where there is a uniform magnetic field \vec{B} directed parallel to the plane of the loop, calculate the magnitude of the magnetic torque on the loop.

27.73 •• BIO Determining Diet. One method for determining the amount of corn in early Native American diets is the *stable isotope ratio analysis* (SIRA) technique. As corn photosynthesizes, it concentrates the isotope carbon-13, whereas most other plants concentrate carbon-12. Overreliance on corn consumption can then be correlated with certain diseases, because corn lacks the essential amino acid lysine. Archaeologists use a mass spectrometer to separate the ^{12}C and ^{13}C isotopes in samples of human remains. Suppose you use a velocity selector to obtain singly ionized (missing one electron) atoms of speed 8.50 km/s, and you want to bend them within a uniform magnetic field in a semicircle of diameter 25.0 cm for the ^{12}C . The measured masses of these isotopes are 1.99×10^{-26} kg (^{12}C) and 2.16×10^{-26} kg (^{13}C). (a) What strength of magnetic field is required? (b) What is the diameter of the ^{13}C semicircle? (c) What is the separation of the ^{12}C and ^{13}C ions at the detector at the end of the semicircle? Is this distance large enough to be easily observed?

27.74 •• CP An Electromagnetic Rail Gun. A conducting bar with mass m and length L slides over horizontal rails that are connected to a voltage source. The voltage source maintains a constant current I in the rails and bar, and a constant, uniform, vertical magnetic field \vec{B} fills the region between the rails (Fig. P27.74). (a) Find the magnitude and direction of the net force on the conducting bar. Ignore friction, air resistance, and electrical resistance. (b) If the bar has mass m , find the distance d that the bar must move along the rails from rest to attain speed v . (c) It has been suggested that rail guns based on this principle could accelerate payloads into earth orbit or beyond. Find the distance the bar must travel along the rails if it is to reach the escape speed for the earth (11.2 km/s). Let $B = 0.80$ T, $I = 2.0 \times 10^3$ A, $m = 25$ kg, and $L = 50$ cm. For simplicity assume the net force on the object is equal to the magnetic force, as in parts (a) and (b), even though gravity plays an important role in an actual launch in space.

Figure P27.74

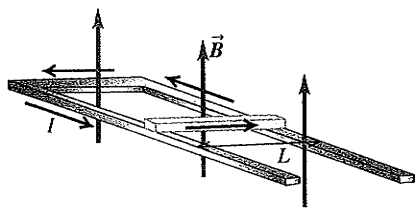

27.75 • A long wire carrying a 6.00-A current reverses direction by means of two right-angle bends, as shown in Fig. P27.75. The part of the wire where the bend occurs is in a magnetic field of 0.666 T confined to the circular region of diameter 75 cm, as shown. Find the magnitude and direction of the net force that the magnetic field exerts on this wire.

Figure P27.75

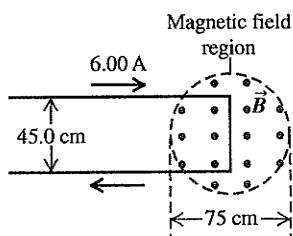

27.76 • A wire 25.0 cm long lies along the z -axis and carries a current of 7.40 A in the $+z$ -direction. The magnetic field is uniform and has components $B_x = -0.242$ T, $B_y = -0.985$ T, and $B_z = -0.336$ T. (a) Find the components of the magnetic force on the wire. (b) What is the magnitude of the net magnetic force on the wire?

27.77 •• CP The rectangular loop of wire shown in Fig. P27.77 has a mass of 0.15 g per centimeter of length and is pivoted about side ab on a frictionless axis. The current in the wire is 8.2 A in the direction shown. Find the magnitude and direction of the magnetic field parallel to the y -axis that will cause the loop to swing up until its plane makes an angle of 30.0° with the yz -plane.

Figure P27.77

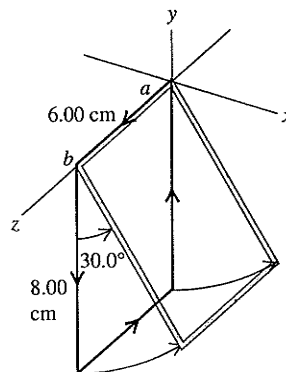

27.78 •• The rectangular loop shown in Fig. P27.78 is pivoted about the y -axis and carries a current of 15.0 A in the direction indicated. (a) If the loop is in a uniform magnetic field with magnitude 0.48 T in the $+x$ -direction, find the magnitude and direction of the torque required to hold the loop in the position shown. (b) Repeat part (a) for the case in which the field is in the $-z$ -direction. (c) For each of the above magnetic fields, what torque would be required if the loop were pivoted about an axis through its center, parallel to the y -axis?

Figure P27.78

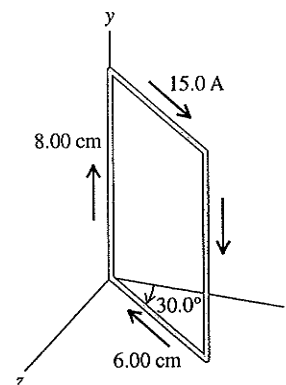

27.79 •• CP CALC A thin, uniform rod with negligible mass and length 0.200 m is attached to the floor by a frictionless hinge at point P (Fig. P27.79). A horizontal spring with force constant $k = 4.80$ N/m connects the other end of the rod to a vertical wall. The rod is in a uniform magnetic field $B = 0.340$ T directed into the plane of the figure. There is current $I = 6.50$ A in the rod, in the direction shown.

Figure P27.79

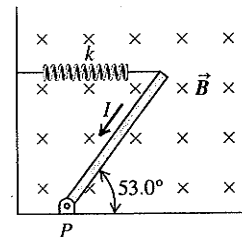

(a) Calculate the torque due to the magnetic force on the rod, for an axis at P . Is it correct to take the total magnetic force to act at the center of gravity of the rod when calculating the torque? Explain. (b) When the rod is in equilibrium and makes an angle of 53.0° with the floor, is the spring stretched or compressed? (c) How much energy is stored in the spring when the rod is in equilibrium?

27.80 •• The loop of wire shown in Fig. P27.80 forms a right triangle and carries a current $I = 5.00$ A in the direction shown. The loop is in a uniform magnetic field that has magnitude $B = 3.00$ T and the same direction as the current in side PQ of the loop. (a) Find the force exerted by the magnetic field on each side of the triangle. If the force is not zero, specify its direction. (b) What is the net force on the loop? (c) The loop is pivoted about an axis that lies

along side PR . Use the forces calculated in part (a) to calculate the torque on each side of the loop (see Problem 27.79). (d) What is the magnitude of the net torque on the loop? Calculate the net torque from the torques calculated in part (c) and also from Eq. (27.28). Do these two results agree? (e) Is the net torque directed to rotate point Q into the plane of the figure or out of the plane of the figure?

Figure P27.80

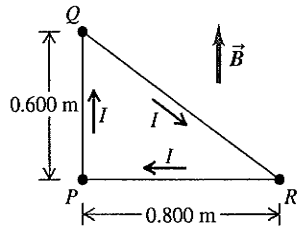

27.81 •• CP A uniform, 458-g metal bar 75.0 cm long carries a current I in a uniform, horizontal 1.25-T magnetic field as shown in Fig. P27.81. The directions of I and \vec{B} are shown in the figure. The bar is free to rotate about a frictionless hinge at point b . The other end of the bar rests on a conducting support at point a but is not attached there. The bar rests at an angle of 60.0° above the horizontal. What is the largest value the current I can have without breaking the electrical contact at a ? (See Problem 27.77.)

Figure P27.81

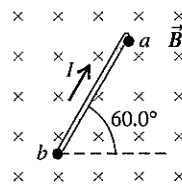

27.82 •• Paleoclimate. Climatologists can determine the past temperature of the earth by comparing the ratio of the isotope oxygen-18 to the isotope oxygen-16 in air trapped in ancient ice sheets, such as those in Greenland. In one method for separating these isotopes, a sample containing both of them is first singly ionized (one electron is removed) and then accelerated from rest through a potential difference V . This beam then enters a magnetic field B at right angles to the field and is bent into a quarter-circle. A particle detector at the end of the path measures the amount of each isotope. (a) Show that the separation Δr of the two isotopes at the detector is given by

$$\Delta r = \frac{\sqrt{2eV}}{eB} (\sqrt{m_{18}} - \sqrt{m_{16}})$$

where m_{16} and m_{18} are the masses of the two oxygen isotopes, (b) The measured masses of the two isotopes are 2.66×10^{-26} kg (^{16}O) and 2.99×10^{-26} kg (^{18}O). If the magnetic field is 0.050 T, what must be the accelerating potential V so that these two isotopes will be separated by 4.00 cm at the detector?

27.83 •• CALC A Voice Coil. It was shown in Section 27.7 that the net force on a current loop in a uniform magnetic field is zero. The magnetic force on the voice coil of a loudspeaker (see Fig. 27.28) is nonzero because the magnetic field at the coil is not uniform. A voice coil in a loudspeaker has 50 turns of wire and a diameter of 1.56 cm, and the current in the coil is 0.950 A.

Figure P27.83

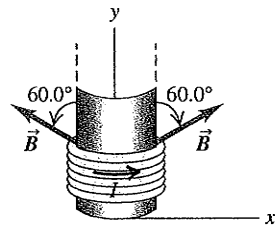

Assume that the magnetic field at each point of the coil has a constant magnitude of 0.220 T and is directed at an angle of 60.0° outward from the normal to the plane of the coil (Fig. P27.83). Let the axis of the coil be in the y -direction. The current in the coil is in the direction shown (counterclockwise as viewed from a point above the coil on the y -axis). Calculate the magnitude and direction of the net magnetic force on the coil.

27.84 •• Quark Model of the Neutron. The neutron is a particle with zero charge. Nonetheless, it has a nonzero magnetic moment with z -component 9.66×10^{-27} A \cdot m 2 . This can be explained by the internal structure of the neutron. A substantial body of evidence indicates that a neutron is composed of three fundamental particles called *quarks*: an “up” (u) quark, of charge $+2e/3$, and two “down” (d) quarks, each of charge $-e/3$. The combination of the three quarks produces a net charge of $2e/3 - e/3 - e/3 = 0$. If the quarks are in motion, they can produce a nonzero magnetic moment. As a very simple model, suppose the u quark moves in a counterclockwise circular path and the d quarks move in a clockwise circular path, all of radius r and all with the same speed v (Fig. P27.84). (a) Determine the current due to the circulation of the u quark. (b) Determine the magnitude of the magnetic moment due to the circulating u quark. (c) Determine the magnitude of the magnetic moment of the three-quark system. (Be careful to use the correct magnetic moment directions.) (d) With what speed v must the quarks move if this model is to reproduce the magnetic moment of the neutron? Use $r = 1.20 \times 10^{-15}$ m (the radius of the neutron) for the radius of the orbits.

Figure P27.84

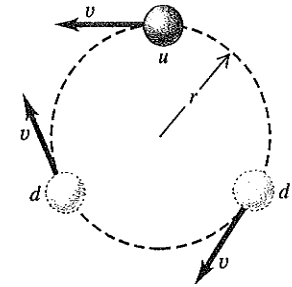

27.85 •• CALC Force on a Current Loop in a Nonuniform Magnetic Field. It was shown in Section 27.7 that the net force on a current loop in a uniform magnetic field is zero. But what if \vec{B} is not uniform? Figure P27.85 shows a square loop of wire that lies in the xy -plane. The loop has corners at $(0, 0)$, $(0, L)$, $(L, 0)$, and (L, L) and carries a constant current I in the clockwise direction. The magnetic field has no x -component but has both y - and z -components: $\vec{B} = (B_0z/L)\hat{j} + (B_0y/L)\hat{k}$, where B_0 is a positive constant. (a) Sketch the magnetic field lines in the yz -plane. (b) Find the magnitude and direction of the magnetic force exerted on each of the sides of the loop by integrating Eq. (27.20). (c) Find the magnitude and direction of the net magnetic force on the loop.

Figure P27.85

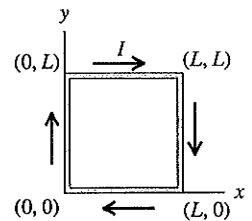

27.86 • CALC Torque on a Current Loop in a Nonuniform Magnetic Field. In Section 27.7 the expression for the torque on a current loop was derived assuming that the magnetic field \vec{B} was uniform. But what if \vec{B} is not uniform? Figure P27.85 shows a square loop of wire that lies in the xy -plane. The loop has corners at $(0, 0)$, $(0, L)$, $(L, 0)$, and (L, L) and carries a constant current I in the clockwise direction. The magnetic field has no z -component but has both x - and y -components: $\vec{B} = (B_0y/L)\hat{i} + (B_0x/L)\hat{j}$, where B_0 is a positive constant. (a) Sketch the magnetic field lines in the xy -plane. (b) Find the magnitude and direction of the magnetic force exerted on each of the sides of the loop by integrating Eq. (27.20). (c) If the loop is free to rotate about the x -axis, find the magnitude and direction of the magnetic torque on the loop. (d) Repeat part (c) for the case in which the loop is free to rotate about the y -axis. (e) Is Eq. (27.26), $\vec{\tau} = \vec{\mu} \times \vec{B}$, an appropriate description of the torque on this loop? Why or why not?

27.87 •• CP An insulated wire with mass $m = 5.40 \times 10^{-5}$ kg is bent into the shape of an inverted U such that the horizontal part has a length $l = 15.0$ cm. The bent ends of the wire are partially

immersed in two pools of mercury, with 2.5 cm of each end below the mercury's surface. The entire structure is in a region containing a uniform 0.00650-T magnetic field directed into the page (Fig. P27.87). An electrical connection from the mercury pools is made through the ends of the wires. The mercury pools are connected to a 1.50-V battery and a switch S. When switch S is closed, the wire jumps 35.0 cm into the air, measured from its initial position. (a) Determine the speed v of the wire as it leaves the mercury. (b) Assuming that the current I through the wire was constant from the time the switch was closed until the wire left the mercury, determine I . (c) Ignoring the resistance of the mercury and the circuit wires, determine the resistance of the moving wire.

Figure P27.87

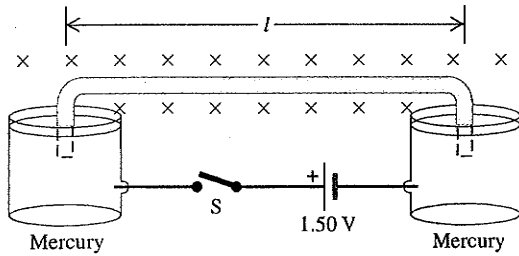

27.88 •• A circular loop of wire with area A lies in the xy -plane. As viewed along the z -axis looking in the $-z$ -direction toward the origin, a current I is circulating clockwise around the loop. The torque produced by an external magnetic field \vec{B} is given by $\vec{\tau} = D(4\hat{i} - 3\hat{j})$, where D is a positive constant, and for this orientation of the loop the magnetic potential energy $U = -\vec{\mu} \cdot \vec{B}$ is negative. The magnitude of the magnetic field is $B_0 = 13D/IA$. (a) Determine the vector magnetic moment of the current loop. (b) Determine the components B_x , B_y , and B_z of \vec{B} .

CHALLENGE PROBLEMS

27.89 ••• A particle with charge $2.15 \mu\text{C}$ and mass $3.20 \times 10^{-11} \text{ kg}$ is initially traveling in the $+y$ -direction with a speed $v_0 = 1.45 \times 10^5 \text{ m/s}$. It then enters a region containing a uniform magnetic field that is directed into, and perpendicular to, the page in Fig. P27.89. The magnitude of the field is 0.420 T. The

Figure P27.89

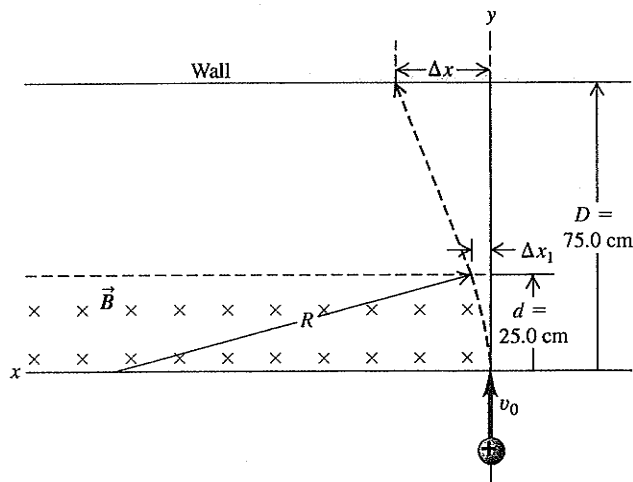

region extends a distance of 25.0 cm along the initial direction of travel; 75.0 cm from the point of entry into the magnetic field region is a wall. The length of the field-free region is thus 50.0 cm. When the charged particle enters the magnetic field, it follows a curved path whose radius of curvature is R . It then leaves the magnetic field after a time t_1 , having been deflected a distance Δx_1 . The particle then travels in the field-free region and strikes the wall after undergoing a total deflection Δx . (a) Determine the radius R of the curved part of the path. (b) Determine t_1 , the time the particle spends in the magnetic field. (c) Determine Δx_1 , the horizontal deflection at the point of exit from the field. (d) Determine Δx , the total horizontal deflection.

27.90 ••• The **Electromagnetic Pump**. Magnetic forces acting on conducting fluids provide a convenient means of pumping these fluids. For example, this method can be used to pump blood without the damage to the cells that can be caused by a mechanical pump. A horizontal tube with rectangular cross section (height h , width w) is placed at right angles to a uniform magnetic field with magnitude B so that a length l is in the field (Fig. P27.90). The tube is filled with a conducting liquid, and an electric current of density J is maintained in the third mutually perpendicular direction.

Figure P27.90

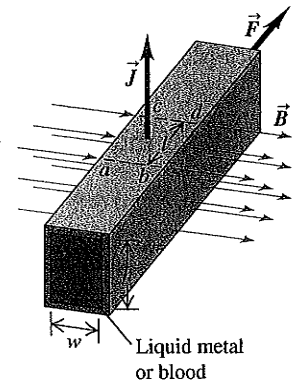

(a) Show that the difference of pressure between a point in the liquid on a vertical plane through ab and a point in the liquid on another vertical plane through cd , under conditions in which the liquid is prevented from flowing, is $\Delta p = JIB$. (b) What current density is needed to provide a pressure difference of 1.00 atm between these two points if $B = 2.20 \text{ T}$ and $l = 35.0 \text{ mm}$?

27.91 ••• **CP A Cycloidal Path**. A particle with mass m and positive charge q starts from rest at the origin shown in Fig. P27.91. There is a uniform electric field \vec{E} in the $+y$ -direction and a uniform magnetic field \vec{B} directed out of the page. It is shown in more advanced books that the path is a *cycloid* whose radius of curvature at the top points is twice the y -coordinate at that level. (a) Explain why the path has this general shape and why it is *repetitive*. (b) Prove that the speed at any point is equal to $\sqrt{2qEy/m}$. (*Hint*: Use energy conservation.) (c) Applying Newton's second law at the top point and taking as given that the radius of curvature here equals $2y$, prove that the speed at this point is $2E/B$.

Figure P27.91

